

KP/КБ1213EHXX-4 (CS-5205XX)

5 A Low Dropout Positive Voltage Regulator

June 1999 - revised November 2002



Features

- Adjustable or Fixed Output
- Output Current of 5A
- Low Dropout, 500 mV at 5A Output Current
- 0.015% Line Regulation
- 0.01% Load Regulation
- 100% Thermal Limit Burn-In
- Fast Transient Response
- Remote Sense

Applications

- High Efficiency Linear Regulators
- Post Regulators for Switching Supplies
- Microprocessor Supply
- Adjustable Power Supply

Description

The CS-5205 series of positive adjustable and fixed regulators are designed to provide 5A with higher efficiency than currently available devices. All internal circuitry is designed to operate down to 500 mV input to output differential and the dropout voltage is fully specified as a function of load current. Dropout voltage of the device is 100 mV at light loads and rising to 500 mV at maximum output current. A second low current input is required to achieve this dropout. The CS-5205 can also be used as a single supply device (3 pin version). On-chip trimming adjusts the reference voltage to 1%. Current limit is also trimmed, minimizing the stress on both the regulator and power source circuitry under overload conditions.

The CS-5205 series are ideal to power the next generation of advanced microprocessor on motherboards where both 5V and 3.3V supplies are available.

Typical application data 2.5V, 5A regulator

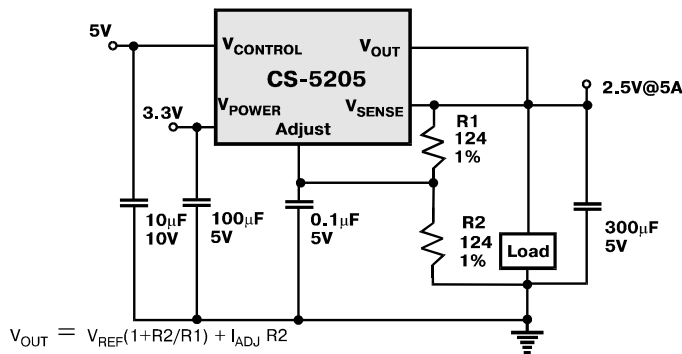

Package information

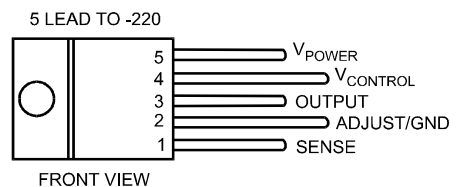
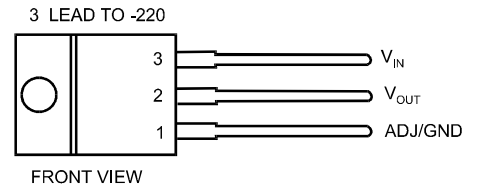

Absolute Maximum Ratings

Symbol	Parameter	Maximum	Units
P_D	Power Dissipation	Internally Limited	W
V_{IN}	Input Voltage V_{power} $V_{control}$	7 13	V
T_J	Operating Junction Temperature Range Control Section Power Transistor	0 to 125 0 to 150	°C
T_{STG}	Storage Temperature	-65 to 150	°C
T_{LEAD}	Lead Temperature (Soldering, 10 sec)	300	°C

Device Selection Guide (Note1)

Device	Output Voltage
CS-5205	Adj
CS-5205-1.5	1.5V
CS-5205-1.8	1.8V
CS-5205-2.5	2.5V
CS-5205-2.85	2.85V
CS-5205-3.0	3.0V
CS-5205-3.3	3.3V
CS-5205-3.5	3.5V
CS-5205-5.0	5.0V

Note 1: Other fixed versions are available $V_{out} = 1.5V$ to $5.0V$

KP/КБ1213EHXX-4 (CS-5205XX)

5 A Low Dropout Positive Voltage Regulator

June 1999 - revised November 2002



Electrical Characteristics (Note 1)

Electrical Characteristics at $I_{LOAD} = 0$ mA and $T_J = +25^\circ\text{C}$ unless otherwise specified.

Parameter	Device	Test Conditions	Min	Typ	Max	Units	
Reference Voltage	CS-5205	$V_{CONTROL} = 2.75\text{V}$, $V_{POWER} = 2\text{V}$, $I_{LOAD} = 10\text{mA}$		1.238	1.250	1.262	V
		$V_{CONTROL} = 2.7\text{V to } 12\text{V}$, $V_{POWER} = 3.3\text{V to } 5.5\text{V}$, $I_{LOAD} = 10\text{mA to } 5\text{A}$	*	1.230	1.250	1.270	
Output Voltage	CS-5205-1.5	$V_{CONTROL} = 4\text{V}$, $V_{POWER} = 2\text{V}$		1.485	1.500	1.515	V
		$V_{CONTROL} = 3\text{V}$, $V_{POWER} = 2.3\text{V}$, $I_{LOAD} = 0\text{mA to } 5\text{A}$	*	1.475	1.500	1.525	
	CS-5205-1.8	$V_{CONTROL} = 4.3\text{V}$, $V_{POWER} = 2.3\text{V}$		1.782	1.800	1.818	V
		$V_{CONTROL} = 3.3\text{V}$, $V_{POWER} = 2.6\text{V}$, $I_{LOAD} = 0\text{mA to } 5\text{A}$	*	1.771	1.800	1.829	
	CS-5205-2.5	$V_{CONTROL} = 5\text{V}$, $V_{POWER} = 3.3\text{V}$		2.475	2.500	2.525	V
		$V_{CONTROL} = 4\text{V}$, $V_{POWER} = 3.3\text{V}$, $I_{LOAD} = 0\text{mA to } 5\text{A}$	*	2.460	2.500	2.540	
	CS-5205-2.85	$V_{CONTROL} = 5.35\text{V}$, $V_{POWER} = 3.35\text{V}$		2.821	2.850	2.879	V
		$V_{CONTROL} = 4.4\text{V}$, $V_{POWER} = 3.7\text{V}$, $I_{LOAD} = 0\text{mA to } 5\text{A}$	*	2.805	2.850	2.895	
CS-5205-3.0	$V_{CONTROL} = 5.5\text{V}$, $V_{POWER} = 3.5\text{V}$		2.970	3.000	3.030	V	
	$V_{CONTROL} = 4.5\text{V}$, $V_{POWER} = 3.8\text{V}$, $I_{LOAD} = 0\text{mA to } 5\text{A}$	*	2.950	3.000	3.050		
CS-5205-3.3	$V_{CONTROL} = 5.8\text{V}$, $V_{POWER} = 3.8\text{V}$		3.267	3.300	3.333	V	
	$V_{CONTROL} = 4.8\text{V}$, $V_{POWER} = 4.1\text{V}$, $I_{LOAD} = 0\text{mA to } 5\text{A}$	*	3.247	3.300	3.353		
CS-5205-3.5	$V_{CONTROL} = 6\text{V}$, $V_{POWER} = 4\text{V}$		3.465	3.500	3.535	V	
	$V_{CONTROL} = 5\text{V}$, $V_{POWER} = 4.3\text{V}$, $I_{LOAD} = 0\text{mA to } 5\text{A}$	*	3.445	3.500	3.555		
CS-5205-5.0	$V_{CONTROL} = 7.5\text{V}$, $V_{POWER} = 5.5\text{V}$		4.950	5.000	5.050	V	
	$V_{CONTROL} = 6.5\text{V}$, $V_{POWER} = 5.8\text{V}$, $I_{LOAD} = 0\text{mA to } 5\text{A}$	*	4.920	5.000	5.080		
Line Regulation	All	$I_{LOAD} = 10\text{mA}$, $(1.5\text{V} + V_{OUT}) \leq V_{CONTROL} \leq 12\text{V}$, $0.8\text{V} \leq (V_{POWER} - V_{OUT}) \leq 5.5\text{V}$	*		0.04	0.20	%
Load Regulation	All	$V_{CONTROL} = V_{OUT} + 2.5\text{V}$, $V_{POWER} = V_{OUT} + 0.8\text{V}$, $I_{LOAD} = 10\text{mA to } 5\text{A}$	*		0.08	0.40	%
Minimum Load Current (Note 2)	CS-5205	$V_{CONTROL} = 5\text{V}$, $V_{POWER} = 3.3\text{V}$, $V_{ADJ} = 0\text{V}$	*		5	10	mA
Control Pin Current (Note3)	All	$V_{CONTROL} = V_{OUT} + 2.5\text{V}$, $V_{POWER} = V_{OUT} + 0.8\text{V}$, $I_{LOAD} = 10\text{mA to } 5\text{A}$	*		80	135	mA
Ground Pin Current	CS-5205-1.5/ -1.8/-2.5/-2.85/ -3.0/-3.3/-3.5/ -5.0	$V_{CONTROL} = V_{OUT} + 2.5\text{V}$, $V_{POWER} = V_{OUT} + 0.8\text{V}$, $I_{LOAD} = 10\text{mA to } 5\text{A}$	*		6	10	mA
Adjust Pin Current	CS-5205	$V_{CONTROL} = 2.75\text{V}$, $V_{POWER} = 2.05\text{V}$, $I_{LOAD} = 10\text{mA}$	*		50	120	μA
Current Limit	All	$(V_{IN} - V_{OUT}) = 3\text{V}$	*	5.5	6.8		A
Ripple Rejection	All	$V_{CONTROL} = V_{POWER} = V_{OUT} + 2.5\text{V}$, $V_{RIPPLE} = 1\text{V}_{P-P}$, $I_{LOAD} = 2.5\text{A}$		60	80		dB
Thermal Regulation	CS-5205	$T_A = 25^\circ\text{C}$, 30 ms pulse			0.003		%/W
Dropout Voltage Note 4							
Control Input ($V_{CONTROL} - V_{OUT}$)	All	$V_{POWER} = V_{OUT} + 0.8\text{V}$, $I_{LOAD} = 10\text{mA}$ $V_{POWER} = V_{OUT} + 0.8\text{V}$, $I_{LOAD} = 5\text{A}$	*		1.00 1.15	1.15 1.30	V
Power Input ($V_{POWER} - V_{OUT}$)	All	$V_{CONTROL} = V_{OUT} + 2.5\text{V}$, $I_{LOAD} = 10\text{mA}$ $V_{CONTROL} = V_{OUT} + 2.5\text{V}$, $I_{LOAD} = 5\text{A}$	*		0.10 0.55	0.17 0.70	V

The * denotes the specifications which apply over the full temperature range.

Note 1: Unless otherwise specified $V_{out} = V_{sense}$. For CS-5205 (adj) $V_{adj} = 0\text{V}$

Note 2: For the adjustable device the minimum load current is the minimum current required to maintain regulation. Normally the current in the resistor divider used to set the output voltage is selected to meet the minimum load current requirement.

Note 3: The control pin current is the drive current required for the output transistor. This current will track output current with a ratio of about 1:100.

Note 4: The dropout voltage for the CS-5205 is caused by either minimum control voltage or minimum power voltage. The specifications represent the minimum input/output voltage required to maintain 1% regulation.

KP/КБ1213EHXX-4 (CS-5205XX)

5 A Low Dropout Positive Voltage Regulator

June 1999 - revised November 2002



Pin Functions (5-Lead)

Sense (Pin 1): This pin is the positive side of the reference voltage. With this pin it is possible to Kelvin sense the output voltage at the load.

Adjust (Pin 2): This pin is the negative side of the reference voltage. Adding a small bypass capacitor from the Adjust pin to ground improves the transient response. For fixed voltage devices the Adjust pin is also brought out to allow the user to add a bypass capacitor.

GND (Pin 2): For fixed voltage devices this is the bottom of the resistor divider that sets the output voltage.

V_{POWER} (Pin 5): This pin is the collector of the power transistor. The output load current is supplied through this pin. The voltage at this pin must be 0.7V greater than the output voltage for the device to regulate.

V_{CONTROL} (Pin 4): This pin is the supply pin for the control circuitry. The current flow into this pin will be about 1% of the output current. The voltage at this pin must be 1.3V greater than the output voltage for the device to regulate.

Output (Pin 3): This is the power output of the device.

Block Diagram

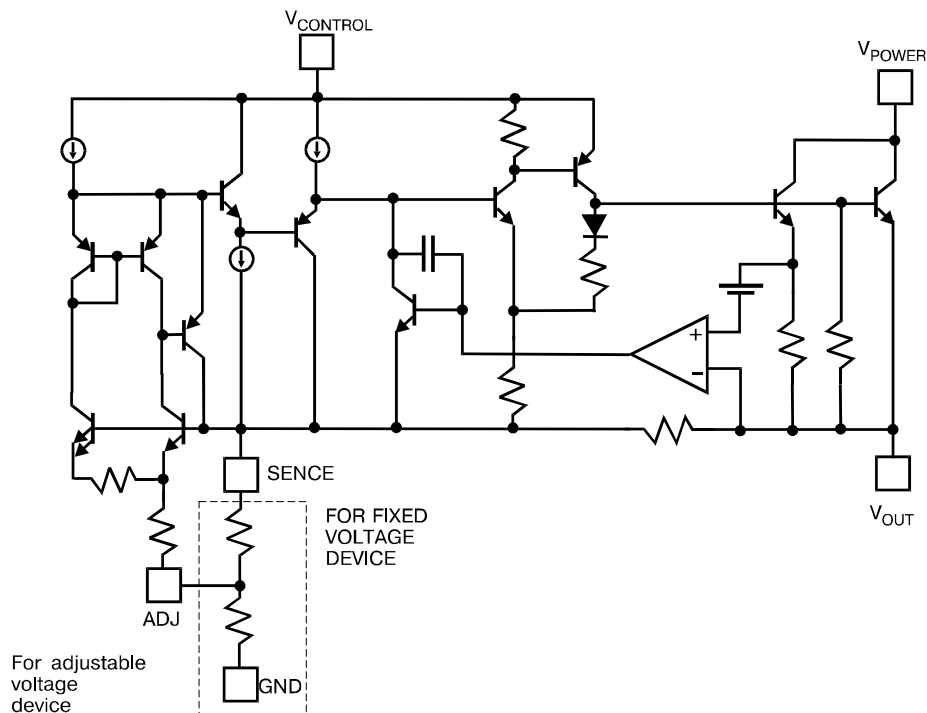

KP/КБ1213EHXX-4 (CS-5205XX)

5 A Low Dropout Positive Voltage Regulator

June 1999 - revised November 2002



Application Information

The CS-5205 series of adjustable and fixed regulators are designed to power the new generation of microprocessors. The CS-5205 is designed to make use of multiple power supplies, present in most systems, to reduce the dropout voltage. One of the advantages of the two supply approach is maximizing the efficiency.

The second supply is at least 1V greater than output voltage and is providing the power for the control circuitry and supplies the drive current to the NPN output transistor. This allows the NPN output transistor to be driven into saturation. For the control voltage the current requirement is small equal to about 1% of the output current or approximately 50 mA for a 5A load. This drive current becomes part of the output current. The maximum voltage on the Control pin is 12V. The maximum voltage at the Power pin is 7V. By tying the control and power inputs together the CS-5205 can also be operated as a single supply device. In single supply operation the dropout will be determined by the minimum control voltage.

The new generation of microprocessors cycle load current from several hundred milliamperes to several amperes in tens of nanoseconds. Output voltage tolerances are tighter and include transient response as part of the specification. Designed to meet the fast current load step requirements of these microprocessors, the CS-5205 also saves total cost by needing less output capacitance to maintain regulation.

Both the fixed and adjustable versions have remote sense pins, permitting very accurate regulation of output voltage. As a result, over an output current range of 100mA to 5A, the typical load regulation is less than 1mV. For the fixed voltages the adjust pin is brought out allowing the user to improve transient response by bypassing the internal resistor divider. Optimum transient response is provided using a capacitor in the range of 0.1 μ F to 1 μ F for bypassing the Adjust pin.

In addition to the enhancements mentioned, the reference accuracy has been improved a factor of two with a guaranteed initial tolerance of $\pm 1\%$ at 25 $^{\circ}$ C and 1.6% accuracy over the full temperature and load current range.

Typical applications for the CS-5205 include 3.3V to 2.5V conversion with a 5V control supply, 5V to 4.2V conversion with a 12V control supply or 5V to 3.6V conversion with a 12V control supply. It is easy to obtain dropout voltages of less than 0.5V at 2.5A along with excellent static and dynamic specifications. The device is fully protected against overcurrent and overtemperature conditions.

Grounding and Output Sensing

The CS-5205 allows true Kelvin sensing for both the high and low side of the load. As a result the voltage regulation at the load can be easily optimized. Voltage drops due to parasitic resistances between the regulator and the load can be placed inside the regulation loop. The advantages of remote sensing are illustrated in figures 1 through 3.

Figure 1 shows the device connected as a conventional 3 terminal regulator with the Sense lead connected directly to the output of the device. R_p is the parasitic resistance of the connections between the device and the load. Trace A of figure 3 illustrates the effect of R_p .

Figure 2 shows the device connected to take advantage of the remote sense feature. The Sense pin and the top of the resistor divider are connected to the top of the load; the bottom of the resistor divider is connected to the bottom of the load. The effect on output regulation can be seen in trace B of figure 3.

It is important to note that the voltage drops due to R_p are not eliminated; they will add to the dropout voltage of the regulator regardless. The CS-5205 can control the voltage at the load as long as the input-output voltage is greater than the total of the dropout voltage of the device plus the voltage drop across R_p .

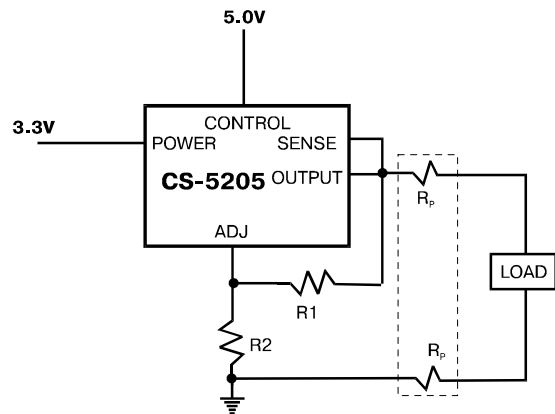

Figure 1. Conventional Load Sensing

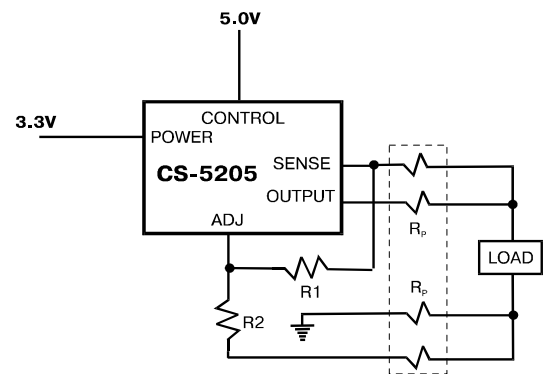

Figure 2. Remote Load Sensing

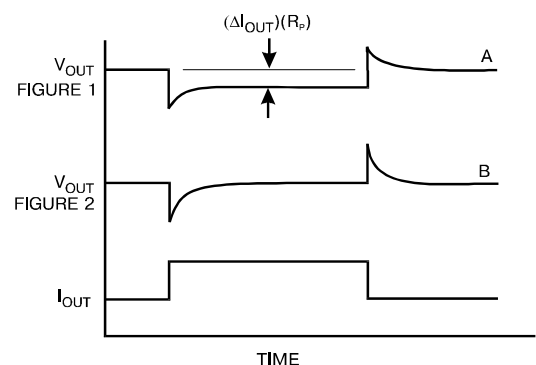

Figure 3. Remote Sensing Improves Load Regulation

Stability

The circuit design used in the CS-5205 series requires the use of an output capacitor as part of the device frequency compensation. The addition of 150 μ F aluminum electrolytic or a 22 μ F solid tantalum on the output will ensure stability for all operating conditions. In order to

KP/КБ1213EHXX-4 (CS-5205XX)

5 A Low Dropout Positive Voltage Regulator

June 1999 - revised November 2002



meet the transient performance of the processor larger value capacitors are needed. To limit the high frequency noise generated by the processor high quality bypass capacitors must be used. In order to limit parasitic inductance (ESL) and resistance (ESR) in capacitors to acceptable limits, multiple small ceramic capacitor in addition to high quality solid tantalum capacitors are required.

When the adjustment terminal is bypassed to improve the ripple rejection, the requirement for an output capacitor increases. The Adjust pin is brought out on the fixed voltage device specifically to allow this capability. To further improve stability and transient response of these devices larger values of output capacitor can be used. The modern processors generate large high frequency current transients.

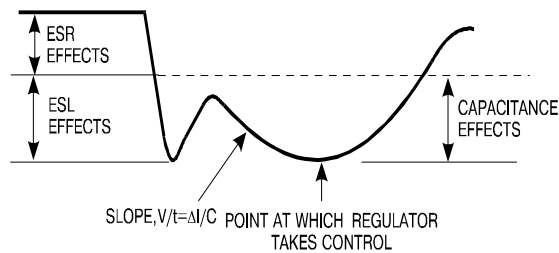
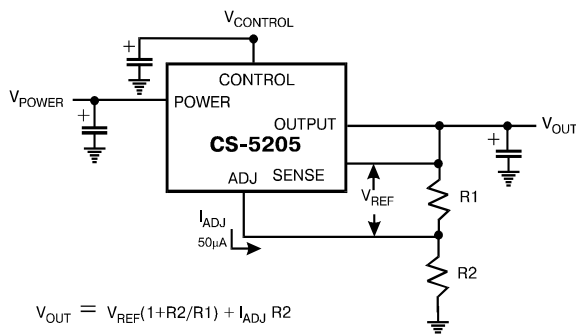

Figure 4.

The load current step contains higher order frequency components than the output coupling network must handle until the regulator throttles to the load current level. Because they contain parasitic resistance and inductance, capacitors are not ideal elements. These parasitic elements dominate the change in output voltage at the beginning of a transient load step change. The ESR of the output capacitors produces an instantaneous step in output voltage $\Delta V = \Delta I(\text{ESR})$. The ESL of the output capacitors produces a droop proportional to the rate of change of the output current $V = L(\Delta I/\Delta t)$. The output capacitance produces a change in output voltage proportional to the time until the regulator can respond $\Delta V = \Delta t(\Delta I/C)$. Figure 4 illustrates these transient effects.

Output Voltage

The CS-5205 (adjustable version) develops a 1.25V reference voltage between the Sense pin and the Adjust pin (Figure 5). Placing a resistor between these two terminals causes a constant current to flow through R1 and down through R2 to set the output voltage. In general R1 is chosen so that this current is the specified minimum load current of 10 mA. The current out of the Adjust pin is small, typically 50 μ A and it adds to the current from R1. For best regulation the top of the resistor divider should be connected directly to the Sense pin.



$$V_{\text{OUT}} = V_{\text{REF}}(1 + R2/R1) + I_{\text{ADJ}} R2$$

Figure 5. Setting Output Voltage

Protection Diodes

In normal operation CS-5205 family does not need any protection diodes between the adjustment pin and the output and from the output to the input to prevent die overstress. Internal resistors are limiting the internal current paths on the ADJ pin. Therefore even with bypass capacitors on the adjust pin no protection diode is needed to ensure device safety under short-circuit conditions. The Adjust pin can be driven on a transient basis $\pm 7V$ with respect to the output without any device degradation.

A protection diode between the Output pin and V_{POWER} pin is not usually needed. Microsecond surge currents of 50A to 100A can be handled by the internal diode between the Output pin and V_{POWER} pin of the device. In normal operations it is difficult to get those values of surge currents even with the use of large output capacitances. Only with high value output capacitors, such as 1000 μ F to 5000 μ F and the V_{POWER} pin is instantaneously shorted to ground, damage can occur. A diode from output to input is recommended (Figure 6).

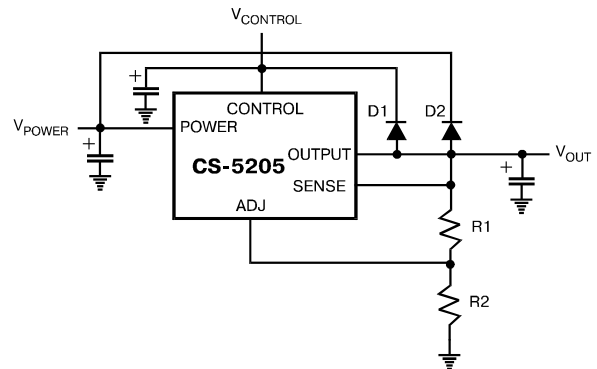

Figure 6. Optional Clamp Diodes Protect Against Input Crowbar Circuits

If CS-5205 is connected as a single supply device with the control and power input pins shorted together the internal diode between the output and the power input pin will protect the control input pin.

Thermal Considerations

The CS-5205 series have internal power and thermal limiting circuitry designed to protect the device under overload conditions. However maximum junction temperature ratings should not be exceeded under continuous normal load conditions. Careful consideration must be given to all sources of thermal resistance from junction to ambient, including junction-to-case, case-to-heat sink interface and heat sink resistance itself.

Junction temperature of the Control section can run up to 125 $^{\circ}$ C. Junction temperature of the Power section can run up to 150 $^{\circ}$ C. Due to the thermal gradients between the power transistor and the control circuitry there is a significant difference in thermal resistance between the Control and Power sections.

Virtually all the power dissipated by the device is dissipated in the power transistor. The temperature rise in the power transistor will be greater than the temperature rise in the Control section making the thermal resistance lower in the Control section. At power levels below 12W the temperature gradient will be less than 25 $^{\circ}$ C and the maximum ambient temperature will be determined by the junction temperature of the Control section. This is due to the lower maximum junction temperature in the Control section. At power levels above 12W the temperature gradient will be greater than 25 $^{\circ}$ C and the maximum ambient temperature will be determined by the Power section. In both cases the junction temperature is

KP/КБ1213EHXX-4 (CS-5205XX)

5 A Low Dropout Positive Voltage Regulator

June 1999 - revised November 2002



determined by the total power dissipated in the device. For most low dropout applications the power dissipation will be less than 12W.

The power in the device is made up of two components: the power in the output transistor and the power in the control circuit.

The power in the control circuit is negligible.

The power in the control circuit is equal to:

$$P_{\text{CONTROL}} = (V_{\text{CONTROL}} - V_{\text{OUT}})(I_{\text{CONTROL}})$$

where I_{CONTROL} is equal $I_{\text{OUT}} / 100(\text{typ})$

The power in the output transistor is equal to:

$$P_{\text{OUTPUT}} = (V_{\text{POWER}} - V_{\text{OUT}})(I_{\text{OUT}})$$

The total power is equal to:

$$P_{\text{TOTAL}} = P_{\text{CONTROL}} + P_{\text{OUTPUT}}$$

Junction-to-case thermal resistance is specified from the IC junction to the bottom of the case directly below the die. This is the lowest resistance path for the heat flow. In order to ensure the best possible thermal flow this area of the package to the heat sink proper mounting is required. Thermal compound at the case-to-heat sink interface is recommended. A thermally conductive spacer can be used, if the case of the device must be electrically isolated, but its added contribution to thermal resistance has to be considered.



Pad Location

CS-5205 Rev.A

only for 3 pin package

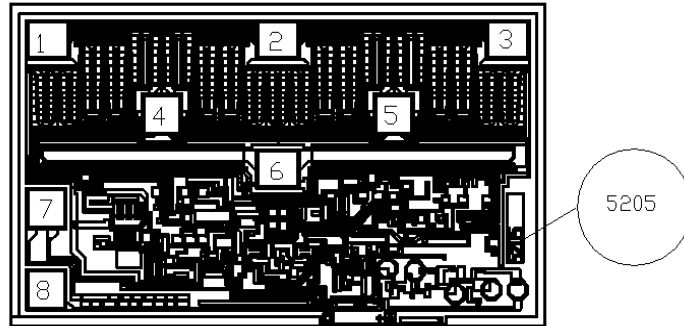

Chip Size 3.1*1.82 mm

Pad N	Pad Name	Pad Center Coordinates (um)
1	Output	205/1625
2	Output	1550/1620
3	Output	2875/1625
4	Vin	875/1200
5	Vin	2225/1200
6	Vin	1550/890
7	Output	205/665
8	Adjust (for adjustable output) GND (for fixed output)	205/205

Other pads are used for trimming

CS-5205 Rev.B

for 3 and 5 pin package

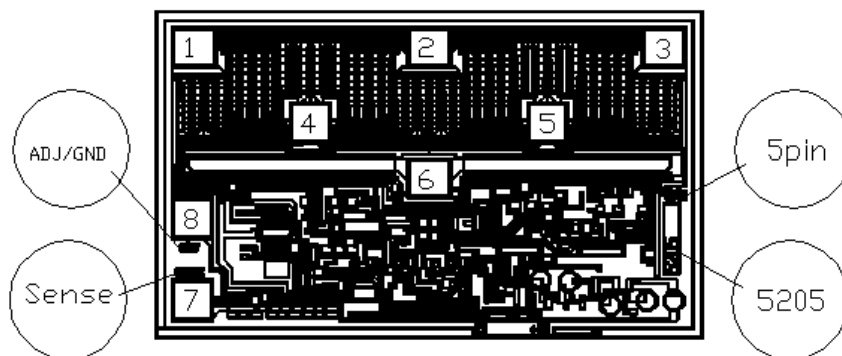

Chip Size 3.1*1.82 mm

Pad N	Pad Name	Pad Center Coordinates (um)
1	Output	205/1625
2	Output	1550/1620
3	Output	2875/1625
4	Vpower (Note1)	875/1200
5	Vpower (Note1)	2225/1200
6	Vcontrol (Note1)	1550/890
7	Sense (Note1)	205/205
8	Adjust (for adjustable output) GND (for fixed output)	205/665

Other pads are used for trimming

Note1: For 3-lead version 4,5,6 pads connect to Vin and 7 pad to Output

CS-5205 Rev. C

for 3 and 5 pin package

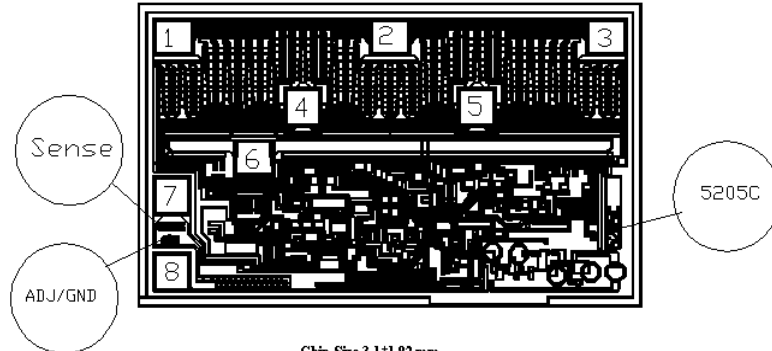

Chip Size 3.1*1.82 mm

Pad N	Pad Name	Pad Center Coordinates (um)
1	Output	205/1625
2	Output	1550/1620
3	Output	2875/1625
4	Vpower (Note 1)	1015/1200
5	Vpower (Note 1)	2095/1200
6	Vcontrol (Note 1)	715/890
7	Sense (Note 1)	205/665
8	Adjust (for adjustable output)	205/205
	GND (for fixed output)	

Other pads are used for trimming

Note1: For 3-lead version 4,5,6 pads connect to Vin and 7 pad to Output