

L48XX
L48XXK

400mA Low Dropout Voltage Regulators

March 1999- revised October 2013



FEATURES

- 400mA output within 2% over temperature
- Very low quiescent current
- Low dropout voltage (420 mV Typ)
- Extremely tight load and line regulation
- Very low temperature coefficient
- Current and thermal limiting
- Unregulated DC input can withstand -20V reverse battery and +60V positive transients
- Direct replacement for SGS-THOMSON-L48XX Series, but has lower ground current, higher accuracy of output voltage and extremely tight load and line regulation. 4-pins versions (fixed model) and 5-pins versions (adjust model) has shutdown input.

APPLICATIONS

- High-efficiency linear regulator
- Battery powered systems
- Portable/Palm top/Notebook computers
- Portable consumer equipment
- Portable Instrumentation
- Automotive Electronics
- SMPS Post-Regulator

Device Selection Guide

Vout, VOLTS	DEVICE
3.3V*	L4833
5V	L4805
8V	L4808
8.5V	L4885
9V	L4809
10V	L4810
12V	L4812
15V	L4815
adj	L48-adj

* - other fixed versions are also available $V_{OUT} = 2.0V$ to $5.0V$
Please consult factory for more information

KC PACKAGE (TOP VIEW)

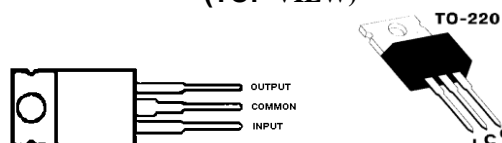

PRODUCT DESCRIPTION

This series of fixed-voltage monolithic micropower voltage regulators is designed for a wide range of applications. This device excellent choice for use in battery-powered application. Furthermore, the quiescent current increases only slightly at dropout, which prolongs battery life.

This series of fixed-voltage regulators features very low quiescent current (100mA Typ.) and very low drop output voltage (Typ. 60mV at light load and 420mV at 400mA). This includes a tight initial tolerance of 0.5% typ., extremely good load and line regulation of 0.05% typ., and very low output temperature coefficient.

This series of fixed-voltage regulators is offered in 3-pin TO-220 package compatible with other fixed-voltage regulators. Adjust model is offered in 5-pin TO-220 package and fixed model with shutdown input is offered in 4-pin TO-220 package.

Absolute Maximum Ratings

Power Dissipation	Internally Limited
Lead Temperature (Soldering,5 seconds)	260°C
Storage Temperature Range	-65°C to+150°C
Operating Junction Temperature Range	-55°C to +150°C
Input Supply Voltage	-20V to +35V
Continuous total dissipation at 25°C free-air temperature	2W
Continuous total dissipation at (or below) 25°C case temperature	15W

L48XX
L48XXK

400mA Low Dropout Voltage Regulators

March 1999- revised October 2013



ELECTRICAL CHARACTERISTICS ($T_J = 25^\circ\text{C}$, $V_{IN} = 14.4\text{V}$, $I_L = 5\text{mA}$, $C_O = 100\mu\text{F}$; unless otherwise noted)

Parameter	Conditions	Min	Typ	Max	Units
Output Voltage	$-25^\circ\text{C} \leq T_J \leq 85^\circ\text{C}$ Full Operating Temperature	$0.985 V_O $ $0.98 V_O $	V_O	$1.015 V_O $ $1.02 V_O $	V
Output Voltage	$1\text{mA} \leq I_L \leq 400\text{mA}$, $T_J \leq T_{J\text{MAX}}$	$0.975 V_O $	V_O	$1.025 V_O $	
Input Supply Voltage				26	
Output Voltage Temperature Coefficient	(Note 1)		50	150	ppm/ $^\circ\text{C}$
Line Regulation (Note 2)	$13\text{V} \leq V_{IN} \leq 26\text{V}$ (Note 3)		0.1	0.4	%
Load Regulation (Note 2)	$1\text{mA} \leq I_L \leq 400\text{mA}$		0.1	0.3	%
Dropout Voltage (Note 4)	$I_L = 150\text{mA}$ $I_L = 400\text{mA}$		200 420	400 700	mV
Ground Current (Note 5)	$I_L = 100\mu\text{A}$ $I_L = 150\text{mA}$ $I_L = 400\text{mA}$		100 12 30	200 20 50	μA mA
Dropout Ground Current (Note 5)	$V_{IN} = V_{OUT} - 0.5\text{V}$, $I_L = 100\mu\text{A}$		200	300	μA
Current Limit	$V_{OUT} = 0$		600	900	mA
Thermal Regulation (Note 6)			0.05	0.2	%/W
Output Noise, 10Hz to 100KHz $I_L = 100\text{mA}$	$C_L = 2.2\mu\text{F}$ $C_L = 3.3\mu\text{F}$ $C_L = 33\mu\text{F}$		500 350 120		$\mu\text{V RMS}$
Ripple Rejection Ratio	$I_O = 350\text{mA}$, $f = 120\text{Hz}$, $C_O = 100\mu\text{F}$, $V_{IN} = V_O + 3\text{V} + 2\text{V}_{pp}$	60			dB
Thermal Shutdown	$1\text{mA} \leq I_L \leq 400\text{mA}$		165		$^\circ\text{C}$
adjust model					
Reference Voltage		1.21	1.235	1.26	V
Reference Voltage	Over Temperature (Note 7)	1.185		1.285	
Feedback Pin Bias Current			20	40	nA
Reference Voltage Temperature Coefficient	(Note 1)		50		ppm/ $^\circ\text{C}$
Feedback Pin Bias Current Temperature Coefficient			0.1		nA/ $^\circ\text{C}$
Shutdown Input					
Input Logic Voltage	Low (Regulator ON) High (Regulator OFF)	2	1.3	0.7	V
Shutdown Pin Input Current	$V_S = 2.4\text{V}$ $V_S = 26\text{V}$		30 450	50 600	
Regulator Output Current in Shutdown	(Note 8)			200	μA

Note 1: Output or reference voltage temperature coefficients defined as the worst case voltage change divided by the total temperature range.

Note 2: Regulations is measured at constant junction temperature, using pulse testing with a low duty cycle. Changes in output voltage due to heating effects are covered under the specification for thermal regulation.

Note 3: Line regulation is tested at 150°C for $I_L = 5\text{mA}$. For $I_L = 100\mu\text{A}$ and $T_J = 125^\circ\text{C}$, line regulation is guaranteed by design to 0.2%. For L4815 $16\text{V} \leq V_{IN} \leq 26\text{V}$.

Note 4: Dropout voltage is defined as the input to output differential at which the output voltage drops 2% below its nominal value measured at 1V differential.

Note 5: Ground pin current is the regulator quiescent current. The total current drawn from the source is the sum of the ground pin current and output load current.

Note 6: Thermal regulation is the change in output voltage at a time T after a change in power dissipation, excluding load or line regulation effects. Specifications are for a 200mA load pulse (3W pulse) for T = 10ms.

Note 7: $V_{ref} \leq V_{OUT} \leq (V_{IN} - 1\text{V})$, $2.3\text{V} \leq V_{IN} \leq 26\text{V}$, $100\mu\text{A} \leq I_L \leq 400\text{mA}$, $T_J \leq T_{J\text{MAX}}$.

Note 8: $V_{\text{shutdown}} \geq 2\text{V}$, $V_{IN} \leq 26\text{V}$, $V_{OUT} = 0\text{V}$.



Block Diagram and Typical Applications
L4805

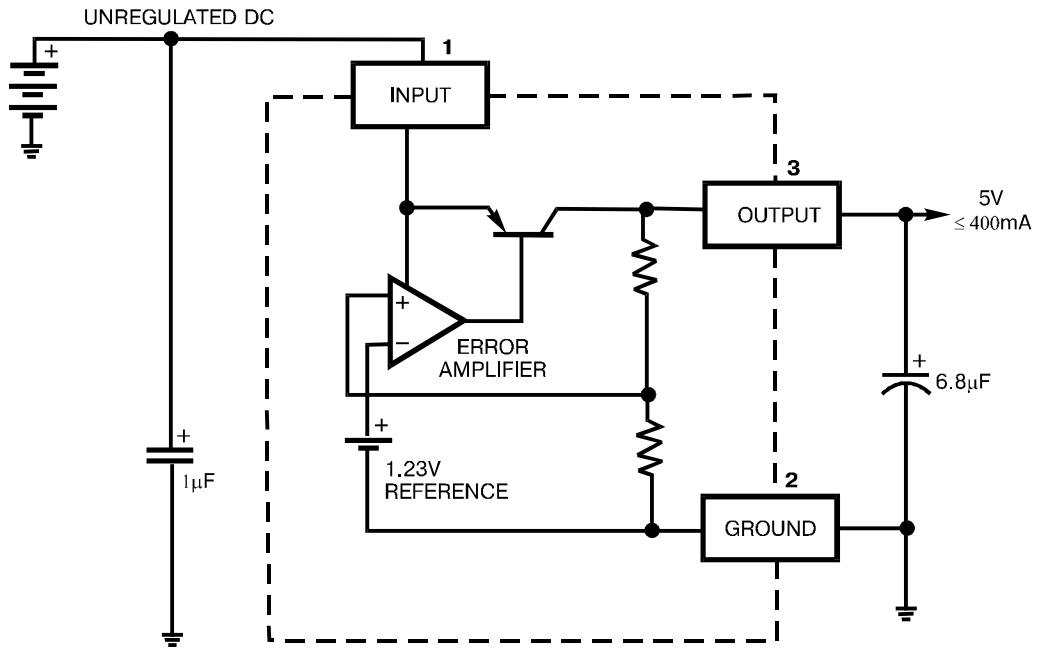
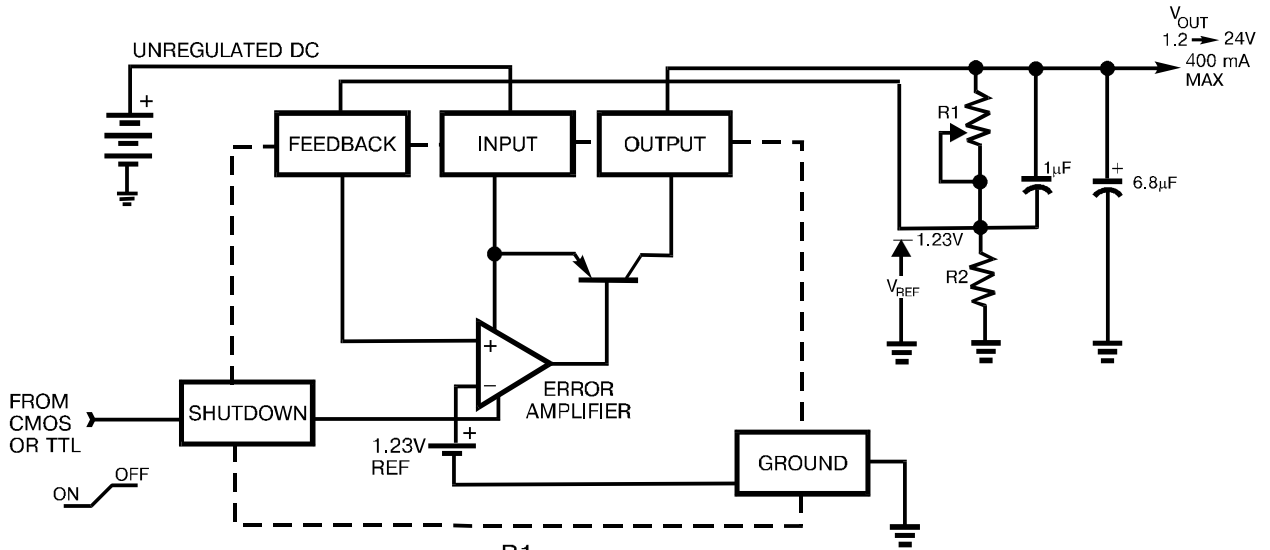

Figure 1. Fixed Regulator

L48-adj



$$V_{out} = V_{REF} \left(1 + \frac{R1}{R2} \right)$$

Figure 2. Adjustable Regulator

L48XX
L48XXK

400mA Low Dropout Voltage Regulators

March 1999- revised October 2013



PAD LOCATION

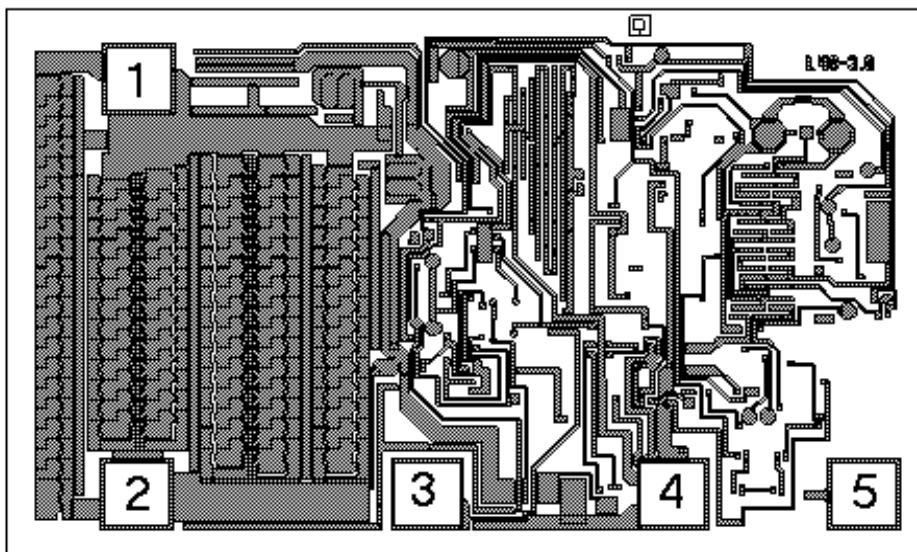

Chip size: $2.57 \times 1.57 \text{ mm}^2$ (include the scribe lines)

The width of the scribe line: $80 \mu\text{m}$

L48XX is produced on 4" wafer
L48XXK is produced on 6" wafer

PAD LOCATION COORDINATES

Pad N	Pad Name	Pad opening size (μm)	Pad center coordinates (μm)	
			X	Y
1	Input	180*180	365	1370
2	Output	180*180	365	180
3	Output (fixed model) Feedback (adjust model)	180*180	1170	180
4	GND	180*180	1855	180
5	Shutdown	180*180	2385	180

L48XX
L48XXK

400mA Low Dropout Voltage Regulators

March 1999- revised October 2013



Assembly Drawing

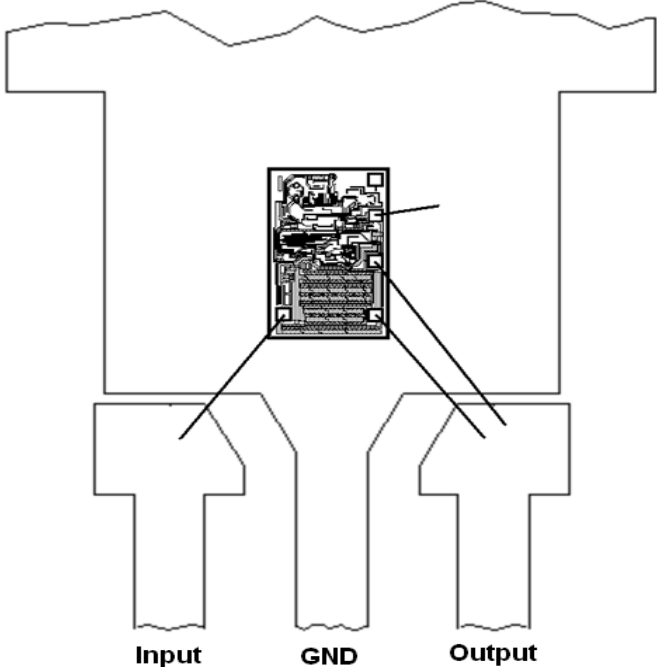

L48XX, L48XXK

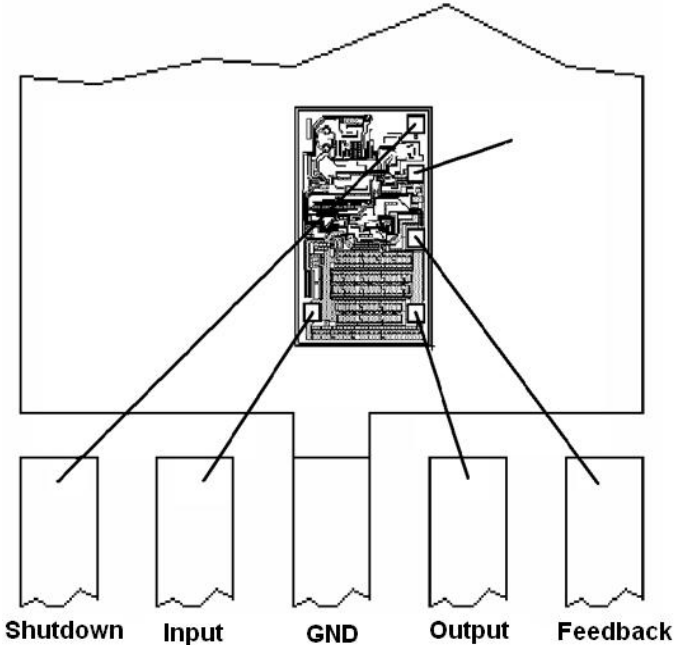

L48 - adj, L48K - adj

The appearance complies with the requirements of the company standards.